



**City of Ashland, Missouri
Meeting Agenda
Board of Aldermen
Ashland, Mo. 65010
7:00 p.m. Tuesday, September 07, 2021**

This meeting will be held via zoom only.

<https://us02web.zoom.us/j/88926284881?pwd=OEFYREJTTnNNQm1kelNlOWdMTW9Bdz09>

I. INTRODUCTORY ITEMS

Invocation
Pledge of Allegiance
Roll Call
Approval of Previous Minutes of August 17, 2021
Approval of Special meeting minutes of August 24, 2021
Adjustment and approval of the Agenda

II. SPECIAL ITEMS

a. None

III. APPOINTMENTS TO BOARD AND COMMISSIONS

a. None

IV. SCHEDULED PUBLIC COMMENT

a. None

(Written request must be received by the City Clerk by Wednesday before the meeting date)
Speakers cannot comment on items on the agenda. Time will be permitted following the reading of each agenda item under Old and New Business for public comment.

V. PUBLIC HEARING

a. Public Hearing-request for annexation from R. Anthony Holdings, LLC of 15.15 acres located off of E. Log Providence Road on Hayes Road, Columbia, Mo.

VI. INTRODUCTION AND FIRST READING

- a. Council Bill No. 2021-050, An ordinance extending the corporate limits of the City of Ashland, Missouri by annexing unincorporated area: Directing the City Clerk to give notice of the annexation.
- b. Council Bill No. 2021-051, an ordinance to amend Chapter 10, Planning, Zoning, Subdivisions, Building of the City of Ashland Code, Section 10.165 Plat Review Mandated.

- c. Council Bill No. 2021-052, an ordinance to amend Chapter 9, Planning and Zoning, of the City of Ashland Code, Section 9.106. Review Plans and Documents Submission, Review Required.

VII. OLD BUSINESS

- a. None

VIII. NEW BUSINESS

- a. A resolution authorizing the purchase of storm water materials
- b. A resolution authorizing the Mayor to enter into an agreement with Christensen Construction Co. for the mill and overlay project; providing for compliance with the prevailing wage law and state mandated construction safety training
- c. Vote to go into closed session after the regular meeting pursuant to Chapter 610.021 (1) legal actions, causes of action or litigation involving a public government body and any confidential or privileged communications between a public governmental body or its representatives and its attorneys.

IX. REPORTS

- a. Mayor's report
- b. City Administrator's report
- c. City Attorney's report
- d. Police Chief's monthly report
- e. Board of Aldermen report

X. GENERAL COMMENTS BY PUBLIC, ALDERMEN AND STAFF

XI. CLOSED SESSION

XII. GO BACK INTO OPEN SESSION-REPORT ACTION TAKEN/IF ANY

XIII. ADJOURNMENT

Members of the public may attend any open meeting. For requests for accommodations related to disability, Please call 573-657-2091 or email cityclerk@ashlandmo.us

In order to assist staff in making the appropriate arrangements for your accommodation, please make sure your request as far in advance of the posted meeting date as possible.

Posted: 9-02-2021 @ 3:45 PM DD

AUGUST 17, 2021
BOARD OF ALDERMEN MINUTES
7:00 P.M.

DRAFT MINUTES NOT APPROVED BY THE BOARD

Mayor Pro-tem Bell called the regular meeting to order at 7:00 p.m. on August 17, 2021 via zoom.

Mayor Pro-tem Bell stated under the invocation we would have a moment of silence for the two staff members that lost family this week.

Mayor Pro-tem Bell led in the pledge of allegiance.

Mayor Pro-tem Bell called the roll:

Ward One: Nathan Volkart-here, Jean Selby-here
Ward Two: Melissa Old-here, Stephanie Bell-here
Ward Three: Rick Lewis-here, Dorise Slinker-here

Staff Present: Darla Sapp, City Clerk, Nathan Nickolaus, City Attorney, Lelande Rehard, Assistant City Administrator, James Creel, Public Works Director and Dan Vandevoorde, Building Inspector.

Mayor Pro-tem Bell presented the minutes of the August 03, 2021 Board meeting for consideration. Alderman Lewis made motion to approve the minutes as presented Alderwoman Old seconded the motion. Mayor Pro-tem Bell called for the vote. Motion carried.

Mayor Pro-tem Bell presented the minutes of the Special Meeting on August 09, 2021 for consideration. Alderwoman Old made motion and seconded by Alderman Lewis to approve the minutes as presented. Mayor Pro-tem Bell called for the vote. Motion carried.

Mayor Pro-tem Bell presented the agenda for adjustments. Alderwoman Old made motion and seconded by Alderman Lewis to approve the agenda. Mayor Pro-tem Bell called for the vote. Motion carried.

Mayor Pro-tem Bell presented Ordinance No. 1375, an ordinance establishing the property tax rate for the City of Ashland for the year 2021 and amending Chapter 5; Tax Rates; Appendix A-1 of the Ashland Municipal Code. Alderwoman Old made motion and seconded by Alderman Lewis to take up Ordinance No. 1375, an ordinance establishing the property tax rate for the City of Ashland for the year 2021 and amending Chapter 5; Tax Rates; Appendix A-1 of the Ashland Municipal Code. Mayor Pro-tem Bell called for the staff report. Lelande Rehard, Assistant City Administrator stated this is the second reading and this is the annual adoption of the property tax rate of 0.204 for the City of Ashland. Mayor Pro-tem Bell called for comments from the public. Mayor Pro-tem Bell called for questions or comments from the Board. Mayor Pro-tem Bell called for the vote. Alderman Lewis-aye, Alderwoman Old-aye, Alderwoman Selby-aye, Alderman Slinker-aye, Alderman Volkart-aye. Motion carried.

Mayor Pro-tem Bell presented a Resolution of intent to award the contract to Christensen Construction for the 2021 Mill and Overlay Street Project. Mayor Pro-tem Bell called for the staff report. Lelande Rehard stated the Board approved for the staff to put this project out for bid. He stated we received one bid from Christensen Construction. James Creel, Public Works Director reported he bid out for the street mill and overlay project and received a sole bid and that was from Christensen Construction. He stated the other contractors did not bid because they could not fit the work in their booked schedules. He reported the bid came in at \$185,827.50. He stated this is approximately 41% of the street repairs, supplies, and maintenance annual budget. He stated their projected cost was \$300,000.00. He stated this bid was set up in a unit manner, which allowed for additional streets to be milled and overlaid as the funds allowed. James

Creel stated we could add some streets at the same pricing. He stated he checked with the company and they are open to this. Mayor Pro-tem called for a motion. Alderwoman Old made motion and seconded by Alderman Lewis to approve the resolution of intent to award the contract to Christensen Construction for the 2021 Mill and Overlay Street Project. Mayor Pro-tem Bell called for the vote. Alderman Lewis-aye, Alderwoman Old-aye, Alderwoman Selby-aye, Alderman Slinker-aye, Alderman Volkart-aye. Motion carried.

Mayor Pro-tem Bell presented a request from the Ashland Parks and Recreation to allow alcohol in the City Park at the September 11, 2021 Fall Festival.

Lelande Rehard, Assistant City Administrator stated that Tracy Banning, Chairman for the Parks and Recreation Board and Marcy Wood were also present on this meeting and could explain this better. Marcy Wood stated they submitted the request for alcohol sales and location layout as well as a little question and answer information sheet. She stated the Fall Festival is scheduled for September 11. She stated the alcohol sales will start at 5:00 p.m. and end at 9:00 p.m. with a band playing. She stated Woody's Pub N Grub is doing the Beer Tent and as applied for their City catering license and are trained for sales and distribution of alcohol sales.

Alderman Lewis stated they have done this many times in the past with no issues.

Alderwoman Old made motion and seconded by Alderwoman Selby to approve the request from the Ashland Parks and Recreation to allow alcohol in the City Park at the September 11, 2021 Fall Festival. Mayor Pro-tem Bell called for the vote. Alderman Lewis-aye, Alderwoman Old-aye, Alderwoman Selby-aye, Alderman Slinker-aye, Alderman Volkart-aye. Motion carried.

Mayor's Report:

Mayor Pro-tem Bell stated she would get with James later. She stated she knows the public works projects are behind schedule but there are smaller projects that need to be completed as well.

City Administrator's Report:

Lelande Rehard reminded the Board of the meeting with Nextsite, the Consultant for Developing Retail and Commercial sector. He stated Mr. Branch will be in attendance and we will host it at 101 West Broadway for the Board and the public will be joining via zoom. He gave an overview of the Missouri Main Street training for next week. He discussed the roundabout project and the comments that it is too low. He stated once it is finished it will make sense. He stated there has been some overruns on this project. Lelande Rehard stated they have received a cost share with MoDot and the EDA grant for the street extension. He discussed the I & I Study Bartlett & West is doing and the study of the northwest sewer. He gave an update on the two software companies for the city staff. Lelande Rehard reported the new Municipal Center remodeling project has begun.

Alderman Slinker stated he has been getting several calls on the roundabout also. He questioned the drop off issue.

Alderwoman Bell asked for an update on census from Lelande Rehard. He stated the census data is out there but not easily accessible.

City Attorney's Report:

Nathan Nickolaus, City Attorney stated he had nothing to report but he informed the Board of the passing of Fred Boeckmann former City Attorney.

Public Works Director Monthly Report:

James Creel, Public Works Director one topic is the roundabout and stated there has been multiple delays with weather, utility relocation and is about 27% complete. He stated there was unsuitable soils under the roadway which led to increased costs. He stated there has been questions of why is it so low. He stated the peak would be taken down on Broadway and the storm water issues will be addressed in the area as well. He asked that they be patient and wait and it will all make since in the end.

James Creel stated the engineering report for Russian Setter Circle has been completed but they are working with Martin Builders timeline to get this underway. He estimated late August or September weather depending. He stated City staff is working on the tennis courts and resurfacing is to start next week and taking approximately one week to complete.

James Creel stated the storm water project on Billy Joe Sapp is moving forward and the materials are currently being bid out.

He stated they are working on a plan for the Caspian Circle detention basin improvements. He stated between Kimberly Drive and Sue Drive they will be replacing the swale to improve the storm water issue.

He stated the Veterans memorial renderings should have been included in their packet. He stated the ground breaking will occur during the Fall Festival and dedication should be on Veteran's Day. He stated they are having a paver campaign and should be organized in the near future. He stated Porter, Berendzen Associates donated the renderings for this project. He stated he is excited about this and it will be a great addition to the entrance to the park.

Board of Aldermen's Reports:

Alderman Slinker reported a nuisance complaint at 115 Church Street. He questioned why some of the comments was removed from the post regarding the rezoning on Hayes Road on the Surveying Ashland Residents facebook page. Alderman Slinker asked for an update on the lawsuit.

Alderman Volkart stated he has been questioned about the property located next to Walk in Faith Church that has had a blue tarp on its roof for several years. He stated he thought we were focusing on cleaning up downtown area. He asked if we have any requirements or time frame these issues get fixed.

Mayor Pro-tem Bell called for additional comments from the public, board or staff.

John Conway, Civil Engineer stated the request for qualifications have went out and should be received by next Wednesday for a large water main replacement project.

Alderwoman Bell stated they are still selling tickets for the Boots and Bows Event through the Southern Boone County PTA and the Ashland Community Club.

Alderwoman Old reported a preliminary drawing for the mural for the Parks Restroom has been approved and the after the final approval by the Parks and Recreation Board it will be drawn out and community will be painting this during the fall festival.

Mayor Pro-tem Bell called for the adjournment.

Alderman Slinker made motion and seconded by Alderman Lewis to adjourn. Mayor Pro-tem Bell called for the vote. Motion carried.

Darla Sapp, City Clerk

Stephanie Bell, Mayor Pro-tem

BOARD OF ALDERMEN SPECIAL MEETING/WORK SESSION
TUESDAY, AUGUST 24, 2021
6:00 P.M.

DRAFT COPY NOT APPROVED BY BOARD

Mayor Sullivan called the special meeting to order at 6:07 p.m. on August 24, 2021.

Mayor Sullivan called the roll:

Ward One: Nathan Volkart-absent, Jean Selby-absent

Ward Two: Melissa Old-here, Stephanie Bell-here

Ward Three: Rick Lewis-here, Dorise Slinker-here

Staff Present: Tony St. Romaine, City Administrator, Lelande Rehard, Assistant City Administrator and Darla Sapp, City Clerk.

Tony St. Romaine introduced Chuck Branch, Consultant for Nextsite.

Chuck Branch thanked Lonna Trammel and Ameren partnership with them. He stated he is exited to work with the City. He gave an overview of his company being a commercial advisory firm that specializes in getting market research and analysis to retailers and restaurants. He stated that we need to start the process with research, support ongoing effort of local business owners and entrepreneurs to provide to them information on Ashland. He stated they will be out there marketing the City of Ashland at conferences and hope to connect developers. He presented data they have gathered from Moser's Grocery Store for a 12 month period. He presented data on the amount of shoppers, times of day of customers, zip codes of shoppers. He gave an update on amount of traffic in the downtown area on a daily basis. He stated this information is useful for people starting a business and current business owners. He also presented a data on the regional trade area retail gap. He stated there is no supply for men's, women's clothing, sporting goods and jewelry. Mr. Branch stated the market analysis contacts support outreach to current and future development opportunities. He stated this is supporting existing local business owners, entrepreneurial and organic growth. He stated this is assisting existing property owners and private investment by connecting developers, tenant, reps, retailers, property owners and broker outreach. He stated they provide conference representation with the next one scheduled in Las Vegas on December 5, 2021. He stated they are expecting normal conferences in 2022.

He called for questions or comments.

Mayor Sullivan asked if this information is sent out to local business that request it. Mr. Branch stated that he wants to make sure this goes through the City so they can be part of the process. Mayor Sullivan asked about gathering data for other restaurants currently in the community to help them succeed.

Lonna Trammel commented on the shoppers at Moser's being from California, Mo being 6.2 percent.

Alderwoman Bell stated a huge struggle is day care in this community. She stated dance programs and other businesses that increase the quality of living in Ashland. She also felt there is a need for drive through food services so you don't have to get the children out of the vehicle.

Tony St. Romaine stated we need to get this information out to local developers and entrepreneurs on these gaps and hopefully spawn some interest.

Alderman Bell suggested the downtown people have a half day conference and tour spaces that are vacant.

Tracy Titmus stated she is the 2021 Chamber President and she asked if they could have access to this information to be able to share.

Bill Lloyd stated he likes the work Mr. Branch is doing and he will continue to support the efforts. He asked that they reach out to Silver Tree Realty, Corey Myers and other individual contractors/developers and share this information with them. Tony St. Romaine, City Administrator stated they have already shared this information with Mr. Branch.

Lonna Trammel asked if they could get updates from him.

Bill Lloyd stated we missed the 5,000 thousand population and asked if this would effect much of what you are doing. Mr. Branch stated it would not since the business would be looking at the regional area.

Mayor Sullivan suggested reaching out to Larry Potterfield and Nick Parks. He stated he wants to support the local. He stated we are growing at a fast rate and he does not want to see vacant lots for 10 years.

Mr. Branch stated it normally takes 18 months from the purchase of property, build out and construction. He stated some retailers open in the fall for the Christmas spending. He stated the business dictates what time frame the business would open.

Alderman Slinker made motion and seconded by Alderman Lewis to adjourn the meeting.

Minutes taken by Darla Sapp, City Clerk

Richard Sullivan, Mayor

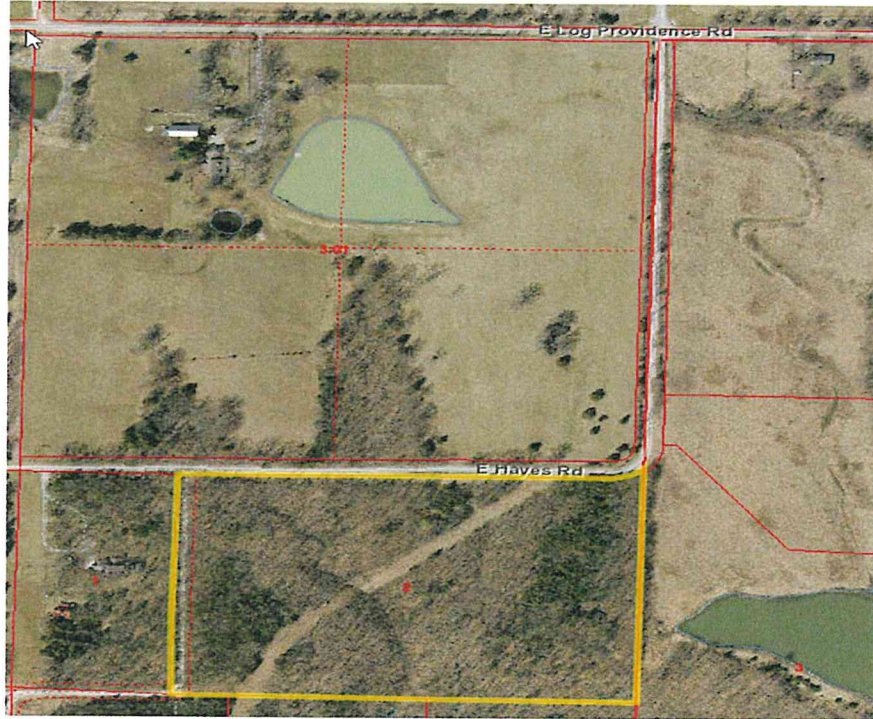

NOTICE OF PUBLIC HEARING

Notice is hereby given that a public hearing will be held before the Board of Aldermen of the City of Ashland, Missouri at 7:00 p.m. on September 07, 2021 via zoom concerning the matter of the proposed annexation into the City limits of the following described real estate in Boone County to wit:

Zoom Link to meeting:

<https://us02web.zoom.us/j/88926284881?pwd=OEFYREJTTnNNQm1keINiOWdMTW9Bdz09>

The voluntary annexation of 15.15 acres located off E. Log Providence Road on E. Hayes Road, Columbia, Mo. for R. Anthony Holdings, LLC. A tract of land in the Northwest Quarter of Section 27, Township 47 North, Range 12 West, Boone County, Missouri records being shown and described as by the Survey recorded October 10, 2017 as instrument No. 2017020867 in Book 4813, Page 183, Records of Boone County, Missouri. 21-800-27-00-002.00 A complete legal description is on file in the City Clerk's office.

At this public hearing any interested person, corporation or political subdivision may present evidence regarding the proposed annexation. Furthermore, any objections to the proposed annexation should be filed in writing with the Board of Aldermen of the City of Ashland no later than fourteen days after the date of said public hearing.

For additional information you can view the documents on the City of Ashland website at www.ashlandmo.us or you contact City Hall at 657-2091 or e-mail cityclerk@ashlandmo.us

Done by order of the Board of Aldermen

Darla Sapp, City Clerk

Publish: 8-18-2021

R. Anthony Development Group, LLC

PO Box 7169

Columbia, MO 65205

Rwolverton65203@gmail.com

573-999-6551

August 26, 2021

City of Ashland, MO
Planning and Zoning Commission

Jerrod Bryan	Nicki Fuemmeler
Cynthia Wills	Luke Baker
Cory Bergthold	Ken Bishop
Jeff Sapp	Tanner Kruger
Scott Dooley	

Members of the Commission,

My name is Robert Wolverton and I am applying on behalf of R. Anthony Property Holdings, LLC for annexation to the City of Ashland and rezoning of 15 acres m/l on E. Hayes Road. The request will come before you at the September 14, 2021 meeting. The following are some of the relevant details regarding this property:

Zoning Request – We are requesting General Commercial zoning for the following reasons:

- 1) This zoning supports our intended use.
- 2) This zoning is consistent with the Ashland Comprehensive Plan.
- 3) This zoning is consistent with the adjoining property to the east.

Intended Use – Our intended use is to build a campus for an organization called St. Raymond's Society (www.srshelp.org). SRS is a not-for-profit entity currently headquartered in Jefferson City, MO and has the following mission statement:

“St. Raymond's Society exists to serve pregnant women and new mothers in need. We provide coaching and resources to assist families in becoming self-sufficient.”

Phase I of the campus would consist of two residential buildings. Each building would house two apartments for a total of four apartments. Each apartment would have four suites for the mothers and the children. This would give a total of sixteen mothers plus their children living there in Phase I. In addition, there would be a child care area intended for the use of the SRS

people – not a public, for-profit daycare. There will be a chapel only for the use of the SRS people. There would be a multi-purpose building with offices, classrooms, storage, a dining room, and a commercial kitchen to be used for teaching the mothers how to be self-sufficient.

All of the structures would be used only for the SRS clientele and staff.

Positive Features of the Property – The property is currently heavily wooded. SRS would clear only what is needed to build their buildings, parking lots, storm water facilities, and any other improvements required by the City of Ashland. This property is located on E. Hayes Road, which is a dead-end street. The leaders of SRS are very protective of the mothers and their children. A property with privacy on a dead-end road gives a higher level of control over the campus and the security of the mothers and staff. The property is located between Columbia and Jefferson City, which is the target area for SRS.

Property Impact – This project will be very low impact. Phase I of the project will use only 3-4 acres of the property. Phase II (two more residential buildings housing another sixteen mothers plus children) will be able to be built in the same area as Phase I and would not impact any more property.

Impact on Surrounding Neighbors – The impact on surrounding neighbors will be minimal. SRS will have its own on-site security and their objective is to have a campus that is quiet, private, secluded, and safe. Ironically, most people who build home on acreage lots also seek a place that is quiet, private, secluded, and safe. There will be a period where road improvements and the initial construction will be disruptive. But once that is done, SRS will be very compatible with surrounding residential properties. We estimate that E. Hayes Road, after improvements, can easily handle the 100 cars per day +/- that we believe SRS will create. **Note: 100 cars per day is a rough estimate and is not based on any traffic study or any other formal study.** We have met with the neighbors and have shared all of this information with the neighbors. One of the neighbors, Ed Musterman, is copied on this correspondence and has the ability to share this with the other neighbors. They have voiced opposition and we believe most of their opposition is fairly or unfairly aimed toward Lakeside Ashland. There are a few neighbors who still resist any kind of development in this area and subscribe to the “Not In My Back Yard” philosophy.

Property Challenges – This property has the same challenges as any other newly developing area. Road improvements, utility improvements, and storm water improvements will be necessary to adequately serve the area. This property is located very close to Lakeside Ashland and will be making all of these improvements as directed by the City of Ashland Public Works Department. We are aware of the concerns regarding emergency access, noise, and other issues. Again, all of these are normal and a newly developing area.

Attached for your review is a map of the property as well as a rough site-plan for SRS. Please note, there will be many adjustments to the site plan as we move further into the process and this is not intended to portray a finished product.

Thank you for your consideration.

Respectfully Submitted,

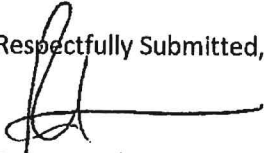
A handwritten signature in black ink, appearing to be 'R. Wolverson', with a long horizontal stroke extending to the right.

Robert Wolverson

Manager

R. Anthony Property Holdings, LLC

CC: Mayor Richard Sullivan
Tony St. Romaine, City Administrator
Ed Musterman

Boone County Internet Parcel Map

Prepared by the Boone County Assessor's Office, (573) 886-4262

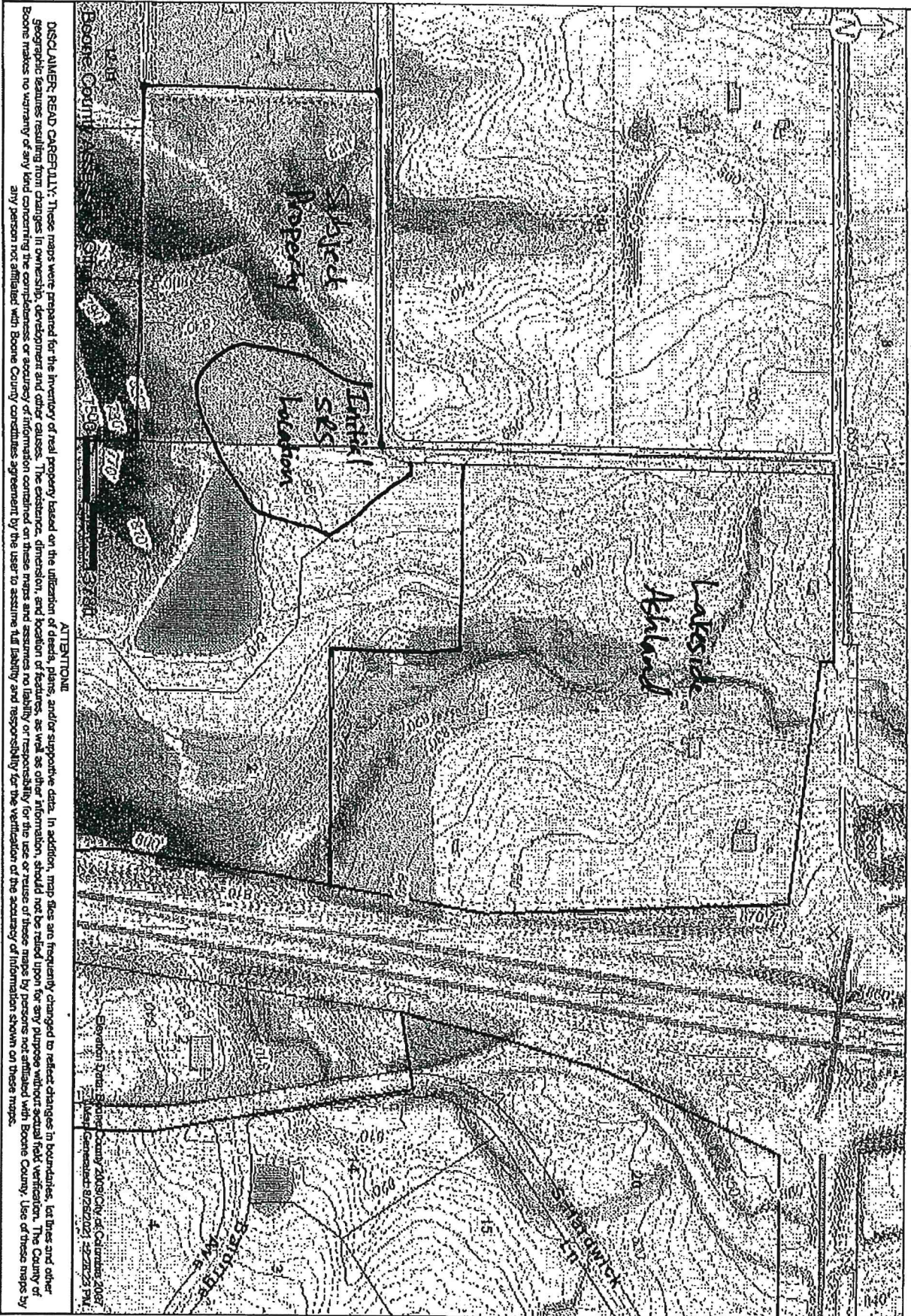

DISCLAIMER READ CAREFULLY: These maps were prepared for the inventory of real property based on the utilization of deeds, plans, and/or supportive data. In addition, map files are frequently changed to reflect changes in boundaries, lot lines and other geographic features resulting from changes in ownership, development and other causes. The existence, dimension, and location of features, as well as other information, should not be relied upon for any purpose without actual field verification. The County of Boone makes no warranty of any kind concerning the completeness or accuracy of information contained on these maps and assumes no liability or responsibility for the use or reuse of these maps by persons not affiliated with Boone County. Use of these maps by any person not affiliated with Boone County constitutes agreement by the user to assume full liability and responsibility for the verification of the accuracy of information shown on these maps.

ATTENTION!

SRS Preliminary Site-Plan

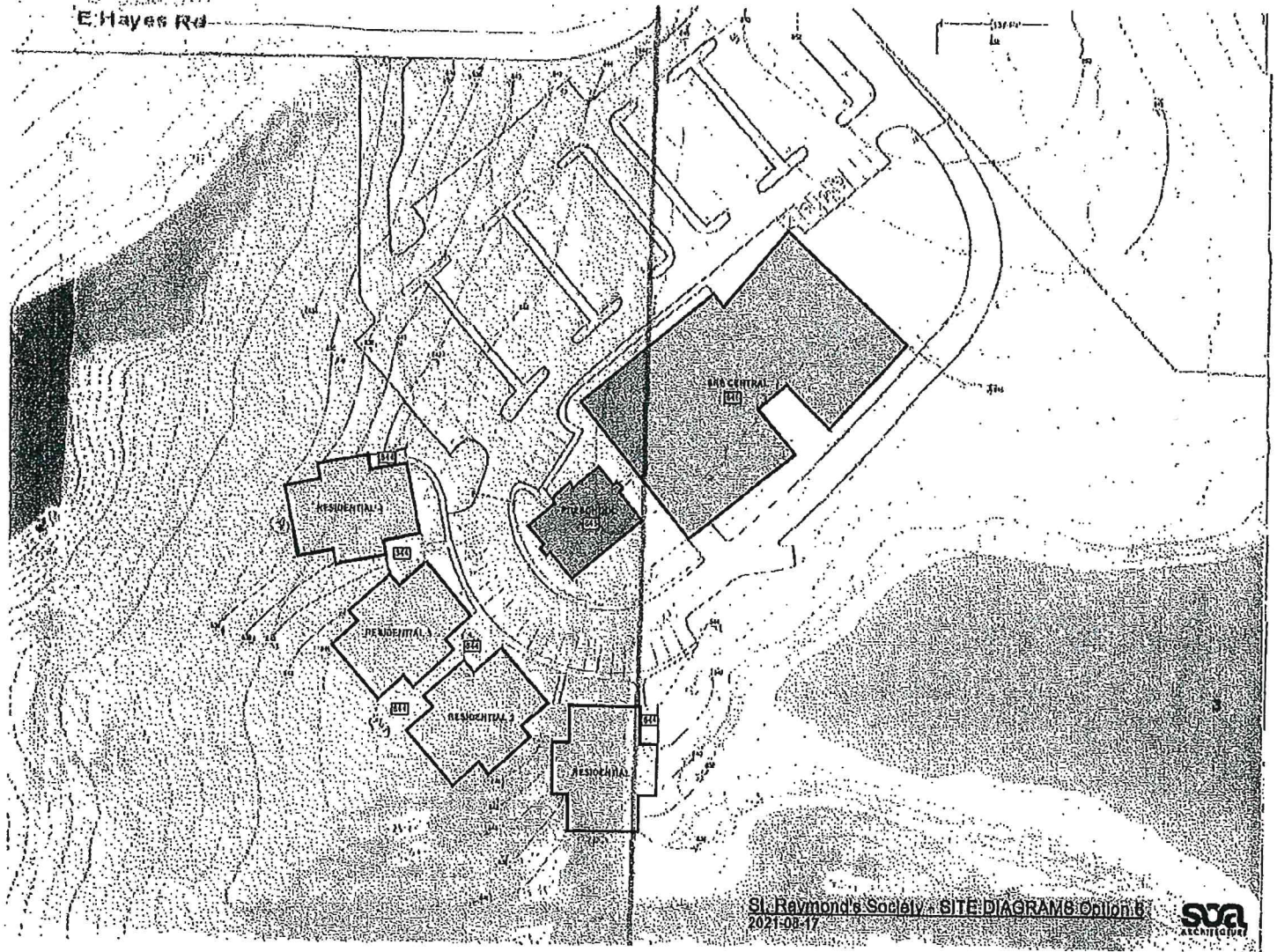

St. Raymond's Society - SITE DIAGRAM Option B
2021-08-17



AN ORDINANCE EXTENDING THE CORPORATE LIMITS OF THE CITY OF ASHLAND, MISSOURI BY ANNEXING UNINCORPORATED AREA; DIRECTING THE CITY CLERK TO GIVE NOTICE OF THE ANNEXATION

BE IT ORDAINED BY THE BOARD OF ALDERMEN OF THE CITY OF ASHLAND, MISSOURI, AS FOLLOWS:

Section 1. The Board of Aldermen hereby finds that a verified petition was filed with the City on August 06, 2021 requesting annexation of land that is contiguous and compact to the existing corporate limits of the City and that is described in Section 4 of this Ordinance. This petition was signed by the owners of the fee interest of record in the land proposed to be annexed. A public hearing was held concerning this matter on September, 07 2021. Notice of this hearing was published more than fourteen days prior to the hearing in a newspaper of general circulation qualified to publish legal matters. At the public hearing all interested persons, corporations and political subdivisions were permitted to present evidence regarding the proposed annexation.

Section 2. The Board of Aldermen determines that the annexation is reasonable and necessary to the proper development of the City and that the City has the ability to furnish normal municipal services to the area to be annexed within a reasonable time.

Section 3. The Board of Aldermen determines that no written objection to the proposed annexation has been filed within fourteen days after the public hearing.

Section 4. The Board of Aldermen hereby extends the city limits by annexing the land described as 15.15 acre tract located off of E. Log Providence Road on E. Hayes Road. The tract of land in the Northwest Quarter of Section 27, Township 47 North, Range 12 West, Boone County records being shown and described as by the Survey recorded October 10, 2017 as instrument No. 2017020867 in Book 4813, Page 183, Records of Boone County, Missouri-Parcel Number 21-800-27-00-002.00. Appendix "A" of Chapter 1 of the City Code is hereby amended to include the land described above.

Section 5. The City Clerk is hereby authorized and directed to cause three certified copies of this ordinance to be filed with the Clerk of Boone County, Missouri and three certified copies with the Assessor of Boone County, Missouri. The City Clerk is further authorized and directed to forward to the Missouri Department of Revenue, by registered or certified mail, a certified copy of this ordinance and a map of the City clearly showing the area annexed into the City.

Section 6. The property described in Exhibit "A" is located in Ward One.

Section 7. This ordinance shall be in full force and effect from and after its passage and approval.

Dated this _____ day of _____, 2021.

Richard Sullivan, Mayor

Attest:

Darla Sapp, City Clerk

Certified as to correct form:

Nathan Nickolaus, City Attorney



City of Ashland

109 East Broadway, Ashland, Missouri 65010

Department Source: Community Development

To: Board of Alderman

From: Dan VandeVoorde

Board Meeting Date: September 7th, 2021

Re: Civil Plan Review Fee

EXECUTIVE SUMMARY:

Proposed language changes to Chapter 9 & 10 of City Code to allow for the City of Ashland to charge civil plan review fees performed by City staff

DISCUSSION:

With the recent hire of a part time civil engineer the City of Ashland will perform civil plan reviews in house. The current Code allows for a 3rd party engineering firm to review civil plans on behalf of the City for code compliance. The ordinance change will keep that provision but also allow us to charge a fee when City staff performs the plan review. I wanted to keep the provision of having a 3rd party do the review based on work load, complexity of the project and staff levels. The fee will be a straight hourly rate of \$80.00/hr. The average rate of 3rd party review firm's is approximately \$140.00/hr. Having a review rate of \$80.00/hr will be beneficial to submitting applicants while still maintaining a good cost recovery for the Community Development. The hours will be billed at the end of the project the same as we currently do with a 3rd party review firm.

FISCAL IMPACT:

Short Term Impact: Varies depending on work load.

Long Term Impact: Varies depending on work load.

SUGGESTED BOARD ACTION:

Staff recommends approval of this Ordinance change.

AN ORDINANCE TO AMEND CHAPTER 10, PLANNING, ZONING, SUBDIVISIONS,
BUILDING OF THE CITY OF ASHLAND CODE

BE IT ORDAINED BY THE BOARD OF ALDERMEN OF THE CITY OF ASHLAND,
MISSOURI, AS FOLLOWS:

Section 1. Chapter 10, Building Code of the City of Ashland, Missouri.

Material to be deleted in ~~strikeout~~; material to be added underlined.

10.065. Plat review mandated

When the Planning Commission of Ashland adopts a city plan which includes at least a major street plan or progresses on its city planning to making and adoption of a major street plan, and files a certified copy of the major street plan in the office of the County Recorder of Boone County, no plat of a subdivision of land lying within the city shall be filed or recorder until it has been submitted to and a report and recommendation thereon made by the Commission to the Board of Aldermen and the Board has approved the plat as provided by law and all costs and fees incurred by the City in having the application reviewed by City staff at a rate of \$80/hr. billed in arrears or by outside providers billed in arrears at their current rate as called for in 11.133, have been reimbursed by the applicant. (Amended Ordinance No. 1240 3-05-2019)

Section 2. This Ordinance shall be in full force after its passage and approval.

Dated this _____ day of _____, 2021.

Richard Sullivan, Mayor

Attest:

Darla Sapp, City Clerk

Certified as to correct form:

Nathan Nickolaus, City Attorney

AN ORDINANCE TO AMEND CHAPTER 9, PLANNING AND ZONING OF THE CITY OF ASHLAND CODE, SECTION 9.106. REVIEW PLANS AND DOCUMENTS SUBMISSION, REVIEW REQUIRED

BE IT RESOLVED BY THE BOARD OF ALDERMEN OF THE CITY OF ASHLAND, MISSOURI, AS FOLLOWS:

Section 1. Chapter 9, Planning and Zoning of the City of Ashland, Missouri.

Material to be deleted in ~~strikeout~~; material to be added underlined.

9.106. Site Plan Submission, Review Required

9.106. Review Plans and Documents Submission, Review Required Any property owner who proposes to develop land within any district, shall submit a set of Review Plans and Documents to the City. Such Review Plans and Documents shall be required when land in district R-1 is subdivided for single family residences but not when an individual lot in District R-1 is developed for a single family residence. Review Plans and Documents shall include the following elements:

- A. Meet the standards of the City of Ashland's long range plan.
- B. Comply with all applicable local, state and federal ordinances, rules, statutes, laws, regulations and requirements.
- C. North arrow and scale. All site plans are to be drawn to a standard engineer's scale. All items shown on the review plan, including, but not limited to, street, driveways, and buildings shall be drawn to scale. The actual scale used will depend on the development and shall be subject to approval of the City Engineer. All sites submitted for review shall be surveyed by a Missouri licensed land surveyor.
- D. Topography and Contours. Existing topography with contours at 5-foot intervals, and delineating any land areas within the 100-year floodplain. Finished grades or contours for entire site (5 or 1-foot contour intervals may be required depending on the site).
- E. Proposed location of buildings and other structures, parking areas, drives, walks, screening, drainage patterns, public streets and any existing easements. Location, width and limits of all existing and proposed sidewalks. Location, size and radii of all existing and proposed median breaks, turning lanes, streets, roadways and parking lots.
- F. All adjacent public street right-of-way, existing and proposed, with centerline location. All adjacent public street and private drive locations, widths, curb cuts and radii (existing and proposed).
- G. Location of all required building and parking setbacks.
- H. Location, dimensions, number of stories and area in square feet of proposed buildings.
- I. Area of land on review plan in square feet or acres.
- J. Limits, location, size and material to be used in all proposed retaining walls.
- K. Location, height, candle power and type of outside lighting fixtures for buildings and parking lots. Illumination Plan overlaid on review plan.
- L. Location, size, type of material and message of all proposed monument or detached signs.

M. Storm water collection, detention, and erosion control plans and calculations.

N. Analysis of the capacity of the existing sanitary sewer receiving system.

O. Building elevations: Elevations of all sides of proposed buildings, including notation indicating building material to be used on exteriors and roofs. Location, size and materials to be used in all screening of rooftop mechanical equipment. P. Traffic Impact Analysis (TIA). A TIA may be required by the City Administrator whose decision is appealable to the Planning and Zoning Commission whose decision is appealable to the Board of Aldermen. In addition, the Planning and Zoning Commission and Board of Aldermen on their own motion may require a TIA. Elements which will be considered in the termination of requiring a TIA, include, but are not limited to:

1. Areas of existing high traffic congestion.

2. Proposed development of a size, i.e., building square footage, number of employees, that a significant increase in area traffic is expected.

The Review Plans and Documents shall be submitted to the City Clerk at least thirty (30) days before the Planning and Zoning Commission meeting at which it will be considered for approval. The City Clerk shall forward the review plans and documents to appropriate city staff and/or consultants who shall review and make a recommendation to the Planning and Zoning Commission for approval or disapproval of the review plan and documents based on whether the plans and documents meet the requirements of this section. The Planning and Zoning Commission shall approve, approve conditionally or disapprove the review plan and documents. If the Commission disapproves the review plans and documents, it shall provide written reasons for disapproval. Review plans and documents disapproval decisions made by the Planning and Zoning Commission may be appealed by the Board of Adjustment as outlined in 10.160.(amended 4-17-2018, Ordinance No. 1177)

Section 2. This Ordinance shall be in full force after its passage and approval.

Dated this _____ day of _____, 2021.

Richard Sullivan, Mayor

Attest:

Darla Sapp, City Clerk

Certified as to correct form:

Nathan Nickolaus, City Attorney



City of Ashland

109 East Broadway, Ashland, Missouri 65010

Department Source: Public Works

To: Board of Alderpersons

From: James Creel, Public Works Director

Board Meeting Date: September 7, 2021

Re: Billy Joe Sapp Dr Stormwater Materials Bid Results and Award

EXECUTIVE SUMMARY:

Authorization is needed to award the Billy Joe Sapp Dr Stormwater Materials Bid to the appropriate vendor(s) and provide them with a Notice to Proceed.

DISCUSSION:

Ashland Public Works (APW) staff recently sent out a bid invitation to multiple vendors for various stormwater materials that will be needed for the Billy Joe Sapp Dr Stormwater Improvement Project.

Vendor	Material	Total
Precision Precast	Inlet & Junction Boxes	\$10,987.74
Champion Precast Inc.	Inlet & Junction Boxes	\$12,402.00
Water and Sewer Supply Inc.	HDPE Pipe	\$16,012.50
Core & Main	HDPE Pipe	\$17,017.50

This RFQ required that these materials would be delivered by 10/27/2021. Ashland Public Works staff will complete the work on this project, with an anticipated start date some time in November 2021 (weather permitting).

FISCAL IMPACT:

Precision Precast's bid of \$10,987.74 for the inlet/junction boxes, along with Water and Sewer Supply Inc.'s bid of \$16,012.50 for the HDPE pipe are the low bids for their portions of the required materials.

The total for both bids is \$27,000.24. This is significantly less than the \$50,000 that was budgeted for these materials, as the materials market has been rather volatile this year.

These bids are competitive with the other received bids and came in lower than was budgeted for this project. Precision Precast and Water and Sewer Supply Inc. are both reputable vendors who have a long history of satisfactory business with the City of Ashland.

SUGGESTED BOARD ACTION:

If the Board of Alderpersons agrees with the staff recommendation, the Mayor should be allowed to enter into contract with Precision Precast and Water and Sewer Supply Inc., and authorize staff to issue a Notice to Proceed.

9-07-2021

A RESOLUTION AUTHORIZING THE PURCHASE OF STORM WATER MATERIALS

WHEREAS, the Staff received the following quotes for storm water materials for the Billy Joe Sapp Drive storm water project:

1. Core & Main-pipe only \$17,017.50
2. Water & Sewer Supply-pipe only \$16,012.50
3. Precision Precast-boxes only-\$10,897.74
4. Champion Precast-boxes only-\$12,402.00

WHEREAS, the City Staff has reviewed the quotes and has recommended the purchase of pipe from Water & Sewer Supply and the purchase of boxes from Precision Precast.

THEREFORE, BE IT RESOLVED BY THE BOARD OF ALDERMEN OF THE CITY OF ASHLAND, MISSOURI AS FOLLOWS:

The Board of Aldermen authorizes the purchase of the storm water material as recommended by the City staff;

Furthermore, the Board of Aldermen has agreed to the terms as set forth in the attached, which by this reference is incorporated herein, as if more fully and completely set out as Exhibit "A".

Passed and adopted this _____ day of _____, 2021.

Richard Sullivan, Mayor

Attest:

Darla Sapp, City Clerk



CONTACT: James Creel, Public Works Director
PHONE NO.: 573-657-2568
E-MAIL: streets@ashlandmo.us

REQUEST FOR QUOTATION FOR STORMWATER MATERIALS

ISSUE DATE: Friday, August 6, 2021

RETURN QUOTATION NO LATER THAN: 2:00 p.m. Friday, August 27, 2021 AT 2:00 PM CENTRAL TIME

QUESTIONS concerning this Request for Quotation may be directed in writing to the City Administrator as shown above.

MAILING INSTRUCTIONS: Print or type the RFQ Description and End Date on the lower left hand corner of the envelope or package. Delivered sealed bids must be in the City Hall office (109 E. Broadway) by the end date and time.

(U.S. Mail)
RETURN QUOTATION TO: CITY OF ASHLAND
PO BOX 135
109 E. BROADWAY
ASHLAND MO 65010

The vendor hereby declares understanding, agreement and certification of compliance to provide the items and/or services, at the prices quoted, in accordance with all requirements and specifications contained herein. The vendor further agrees that the language of this RFQ shall govern in the event of a conflict with his/her proposal. The vendor further agrees that upon receipt of an authorized purchase order from the Purchasing Division or when a Contract is signed and issued by an authorized official of the City of Ashland, a binding contract shall exist between the vendor and the City of Ashland.

SIGNATURE REQUIRED

VENDOR NAME

MAILING ADDRESS

CITY, STATE, ZIP CODE

CONTACT PERSON



"Where Quality Comes First"

Precision Precast
 8400 Trade Center Drive
 Columbia, MO 65201
 Phone: (573) 442-0995
 Fax: (573) 474-4086

Quote Number: 8476

Quote Date: 8/16/2021

Office

Bill to:	City of Ashland Public Works 109 East Broadway Ashland, MO 65010	Project:	BILLY JOE SAPP DRIVE
Contact:	John Fraga	Project Manager:	
Phone :	(573) 657-2568	Fax:	(573) 657-7018
Customer ID:	City of Ashland	ShipVia:	Unassigned
Terms:	NET 30	PO:	
		Sales Rep:	Dave

Structure ID/Product	Structure Type	Qty	Structure Price/Average	Amount
3 X 3 GRATE INLET				
A 2	Storm 3 X 3 GRATE INLET		\$1,822.60	
A 6	Storm 3 X 3 GRATE INLET		\$1,835.73	
A 8	Storm 3 X 3 GRATE INLET		\$1,904.67	
		3	\$1,854.33	\$5,563.00
3 X 3 JCT BOX				
A 10	Storm 3 X 3 JCT BOX		\$1,723.53	
A 12	Storm 3 X 3 JCT BOX		\$1,723.53	
A 4	Storm 3 X 3 JCT BOX		\$1,887.68	
		3	\$1,778.25	\$5,334.74
			Subtotal	\$10,897.74
			Taxable	\$0.00
			Non-Taxable	\$10,897.74
			Sub Total	\$10,897.74
			Tax	\$0.00
			Total	\$10,897.74

All applicable Federal, State and Local taxes will be added to these prices.

Customer Signature _____ Date _____

THANK YOU FOR GIVING PRECISION PRECAST THE OPPORTUNITY TO QUOTE THIS JOB. PRICES GOOD FOR 30 DAYS FROM DATE OF QUOTE.

Net by 30th of month following purchase, 1.5% per month Service Charge on past due accounts. If not within 60 days, account will be placed on C.O.D. basis. 25% handling charge on all merchandise returned. All returns subject to inspection. SPECIAL ORDERS ARE NON-RETURNABLE!

If there are any questions please contact David Rothove at (573) 289-8260, Email: drothove@precision-precast.com or Steve Box at (573) 356-2337, Email: sbox@precision-precast.com.



"Where Quality Comes First"

Precision Precast
 8400 Trade Center Drive
 Columbia, MO 65201
 Phone: (573) 442-0995
 Fax: (573) 474-4086

Quote Number: 8476

Quote Date: 8/16/2021

Office

Bill to:	City of Ashland Public Works 109 East Broadway Ashland, MO 65010	Project:	BILLY JOE SAPP DRIVE
Contact:	John Fraga	Project Manager:	
Phone :	(573) 657-2568	Fax:	(573) 657-7018
Customer ID:	City of Ashland	ShipVia:	Unassigned
Terms:	NET 30	PO:	
		Sales Rep:	Dave
		Phone :	
		Fax:	

Qty	Item	Description	UOM	Unit Price	TX	Extension
Structure: <input type="checkbox"/> A 2 Storm 3 X 3 GRATE INLET						
1	EJ1060Z	1060 Z EJ	EA	\$954.50	<input checked="" type="checkbox"/>	\$954.50
1	JCT 3 X 3 LID	3 X 3 LID NO CASTING	EA	\$208.55	<input checked="" type="checkbox"/>	\$208.55
1	JB-3X3B00	3 X 3 BASE x 30"	VF	\$659.55	<input checked="" type="checkbox"/>	\$659.55
						\$1,822.60

Structure: <input type="checkbox"/> A 6 Storm 3 X 3 GRATE INLET						
1	EJ1060Z	1060 Z EJ	EA	\$954.50	<input checked="" type="checkbox"/>	\$954.50
1	JCT 3 X 3 LID	3 X 3 LID NO CASTING	EA	\$208.55	<input checked="" type="checkbox"/>	\$208.55
1	JB-3X3B00	3 X 3 BASE x 31"	VF	\$672.68	<input checked="" type="checkbox"/>	\$672.68
						\$1,835.73

Structure: <input type="checkbox"/> A 8 Storm 3 X 3 GRATE INLET						
1	EJ1060Z	1060 Z EJ	EA	\$954.50	<input checked="" type="checkbox"/>	\$954.50
1	JCT 3 X 3 LID	3 X 3 LID NO CASTING	EA	\$208.55	<input checked="" type="checkbox"/>	\$208.55
1	JB-3X3B00	3 X 3 BASE x 36"	VF	\$741.62	<input checked="" type="checkbox"/>	\$741.62
						\$1,904.67

Structure: <input type="checkbox"/> A 10 Storm 3 X 3 JCT BOX						
1	EJ1120A	1120 A EJ	EA	\$445.05	<input checked="" type="checkbox"/>	\$445.05
1	JCT 3 X 3 LID	3 X 3 LID NO CASTING	EA	\$208.55	<input checked="" type="checkbox"/>	\$208.55
1	JB-3X3B00	3 X 3 BASE x 60"	VF	\$1,069.93	<input checked="" type="checkbox"/>	\$1,069.93
						\$1,723.53

Structure: <input type="checkbox"/> A 12 Storm 3 X 3 JCT BOX						
1	EJ1120A	1120 A EJ	EA	\$445.05	<input checked="" type="checkbox"/>	\$445.05
1	JCT 3 X 3 LID	3 X 3 LID NO CASTING	EA	\$208.55	<input checked="" type="checkbox"/>	\$208.55
1	JB-3X3B00	3 X 3 BASE x 60"	VF	\$1,069.93	<input checked="" type="checkbox"/>	\$1,069.93
						\$1,723.53

Structure: <input type="checkbox"/> A 4 Storm 3 X 3 JCT BOX						
1	EJ1120A	1120 A EJ	EA	\$445.05	<input checked="" type="checkbox"/>	\$445.05
1	JCT 3 X 3 LID	3 X 3 LID NO CASTING	EA	\$208.55	<input checked="" type="checkbox"/>	\$208.55
1	JB-3X3B00	3 X 3 BASE x 72"	VF	\$1,234.08	<input checked="" type="checkbox"/>	\$1,234.08
						\$1,887.68



"Where Quality Comes First"

Precision Precast
8400 Trade Center Drive
Columbia, MO 65201
Phone: (573) 442-0995
Fax: (573) 474-4086

Quote Number: 8476

Quote Date: 8/16/2021

Office

Total Weight 46,895

Table with 2 columns: Category, Amount. Rows include Taxable (\$0.00), Non-Taxable (\$10,897.74), Sub Total (\$10,897.74), Tax (\$0.00), Total (\$10,897.74).

All applicable Federal, State and Local taxes will be added to these prices.

Customer Signature _____ Date _____

THANK YOU FOR GIVING PRECISION PRECAST THE OPPORTUNITY TO QUOTE THIS JOB. PRICES GOOD FOR 30 DAYS FROM DATE OF QUOTE.

Net by 30th of month following purchase, 1.5% per month Service Charge on past due accounts. If not within 60 days, account will be placed on C.O.D. basis. 25% handling charge on all merchandise returned. All returns subject to inspection. SPECIAL ORDERS ARE NON-RETURNABLE!

If there are any questions please contact David Rothove at (573) 289-8260, Email: drothove@precision-precision.com or Steve Box at (573) 356-2337, Email: sbox@precision-precision.com.



CONTACT: James Creel, Public Works Director
PHONE NO.: 573-657-2568
E-MAIL: streets@ashlandmo.us

REQUEST FOR QUOTATION FOR STORMWATER MATERIALS

ISSUE DATE: Friday, August 6, 2021

RETURN QUOTATION NO LATER THAN: 2:00 p.m. Friday, August 27, 2021 AT 2:00 PM CENTRAL TIME

QUESTIONS concerning this Request for Quotation may be directed in writing to the City Administrator as shown above.

MAILING INSTRUCTIONS: Print or type the RFQ Description and End Date on the lower left hand corner of the envelope or package. Delivered sealed bids must be in the City Hall office (109 E. Broadway) by the end date and time.

(U.S. Mail)

**RETURN QUOTATION TO: CITY OF ASHLAND
PO BOX 135
109 E. BROADWAY
ASHLAND MO 65010**

The vendor hereby declares understanding, agreement and certification of compliance to provide the items and/or services, at the prices quoted, in accordance with all requirements and specifications contained herein. The vendor further agrees that the language of this RFQ shall govern in the event of a conflict with his/her proposal. The vendor further agrees that upon receipt of an authorized purchase order from the Purchasing Division or when a Contract is signed and issued by an authorized official of the City of Ashland, a binding contract shall exist between the vendor and the City of Ashland.

REQUEST FOR QUOTATION FOR FURNISHING STORMWATER MATERIALS

SIGNATURE REQUIRED

VENDOR NAME Water & Sewer Supply, Inc.	
MAILING ADDRESS 2612 Paris Road	
CITY, STATE, ZIP CODE Columbia MO 65202	
CONTACT PERSON Adam Ransdell	EMAIL ADDRESS adamwatersewer@gmail.com
PHONE NUMBER 573-474-8473	FAX NUMBER
AUTHORIZED SIGNATURE Adam Ransdell	DATE 08/26/2021
PRINTED NAME Adam Ransdell	TITLE Salesman

Section I

THE UNDERSIGNED BIDDER, having examined the specifications, general requirements and other proposed contract documents, and all addenda thereto,

HEREBY PROPOSES the following materials, equipment or supplies listed in accordance with the proposed specifications.

All prices stated herein are firm. Missouri Sales and Use Tax are not to be included in this pricing. All prices shall be quoted FOB Destination, Ashland, MO.

Item No.	Description	Estimated Quantity	Unit	Unit Pricing	Total Price
1	24" Diameter HDPE Pipe	750	Linear Feet	21.35	16,012.50
2	3'x3' Junction Box	3	Each	NO BID	—
3	3'x3' Grated Inlet Box	3	Each	NO BID	—
Total Base Bid					16,012.50

REQUEST FOR QUOTATION FOR FURNISHING STORMWATER MATERIALS

Section II

2.0 Specifications & Plans:

This specification shall cover all materials for a designated storm water project within the City of Ashland, MO as described in this section.

2.1 Materials

The City of Ashland, Missouri, hereafter referred to as "City", proposes to contract for the furnishing of all materials, and delivery of such items for stormwater repair work required of the bid items listed in Section I.

High Density Poly Ethylene Pipe (HDPE): All HDPE pipe shall conform to AASHTO M294. HDPE pipe to be ADS N-12 WT IB (water tight, integral bell) smooth interior, dual wall or approved equal. All HDPE pipe shall contain a minimum content of 2% carbon black as required by ASTM D3350. Pipe shall be furnished with an integral reinforced bell with a bell tolerance device and elastomeric gasket to meet ASTM D477 and ASTM D3212. Pipe shall be joined using a bell & spigot joint meeting AASHTO M252, AASHTO M294 or ASTM F2306. The joint shall be water-tight and gaskets, when applicable, shall meet the requirements of ASTM F477. Gaskets shall be factory installed with a removable wrap to ensure gasket is free from debris. A joint lubricant supplied by the manufacturer shall be used on the gasket and bell during assembly. Field joints shall provide circumferential and longitudinal strength to maintain the pipe alignment, prevent separation of pipe and prevent infiltration of fill material.

Technical drawings in Appendix A shall be referenced for the remaining materials in this bid.

2.2 Delivery

All bids submitted shall include delivery. Materials shall be delivered via truck/trailer to the following location:

City of Ashland Public Works Department, 500 Commerce Dr Ashland, MO 65010

The unit prices quoted shall include **ALL** delivery and unloading expenses. Ashland Public Works staff will be available to offload materials with on-site equipment. End gate service will not be necessary.

All deliveries are to be made during normal working hours unless prior arrangements have been made with the purchaser's designated representative(s). Deliveries will not be accepted on Saturdays, Sundays or Holidays, unless mutual agreement has been reached between the vendor and/or hauler and the City's designated representative(s).

All materials shall be delivered by October 27, 2021, unless otherwise indicated by the City.

The supplier (or hauler) shall give the City at least twenty-four (24) hours' notice prior to making delivery to public works facility.

In the event vendor does not expect to meet the contract delivery date and time requirements, the City should be notified of the delay. Vendor may request delivery times not normally allowed under the terms of the

REQUEST FOR QUOTATION FOR FURNISHING STORMWATER MATERIALS

contract when situations warrant. Any changes in scheduled deliveries must be approved by City's designated representative(s).

Section III

3.1 Non Collusion:

In submitting this quotation, the Undersigned declares that the only persons or parties interested in the quotation as principals are those named herein and that the quotation is made without collusion with any other person, firm or corporation.

3.2 Addendum(s):

The Undersigned acknowledges that he/she has received a complete set of the RFQ and the contract documents and receipt of the following Addenda:

Addendum No. and Date

_____	_____
_____	_____

3.3 Validity of Bids:

In submitting this bid it is understood that the right is reserved by the City, to reject any and all bids and it is agreed that the bids may not be withdrawn for a period of ninety (90) days from the specified time for receiving bids.

3.4 HOLD HARMLESS AGREEMENT:

To the fullest extent not prohibited by law, Contractor shall indemnify and hold harmless the City of Ashland, its directors, officers, agents, and employees from and against all claims, damages, losses, and expenses (including but not limited to attorney's fees) arising by reason of any act or failure to act, negligent or otherwise, of Contractor, of any subcontractor (meaning anyone, including but not limited to consultants having a contract with Contractor or a subcontractor for part of the services), of anyone directly or indirectly employed by Contractor or by any subcontractor, or of anyone for whose acts the Contractor or its subcontractor may be liable, in connection with providing these services. This provision does not, however, require Contractor to indemnify, hold harmless, or defend the City of Ashland from its own negligence.

Each set of bids shall be plainly headed with the name and address of the Bidder. In case the bid is made by a corporation, the same shall be signed by a legally authorized agent of the corporation. The envelope containing the bids shall be sealed and plainly marked as a bid for: **STORMWATER MATERIALS**

REQUEST FOR QUOTATION FOR FURNISHING STORMWATER MATERIALS

Appendix A:

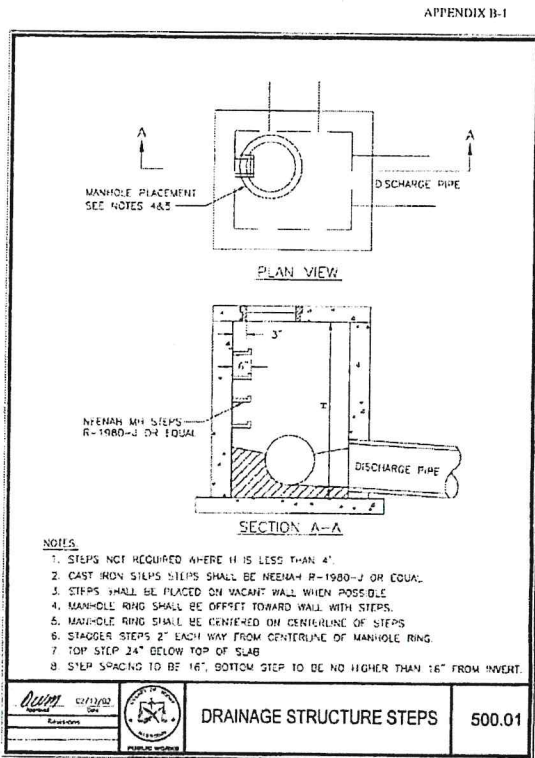

190

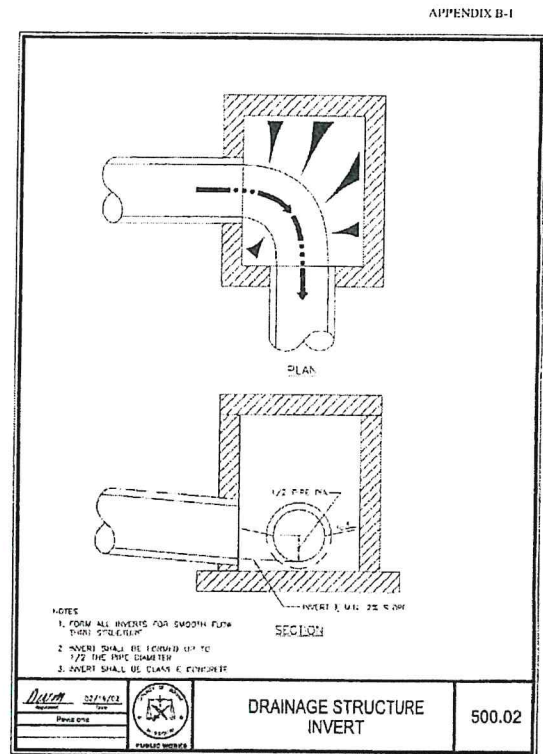

191

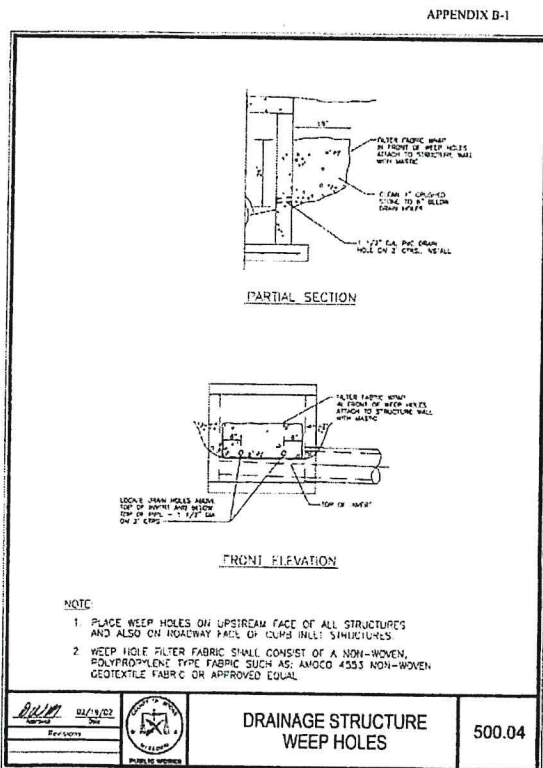

193

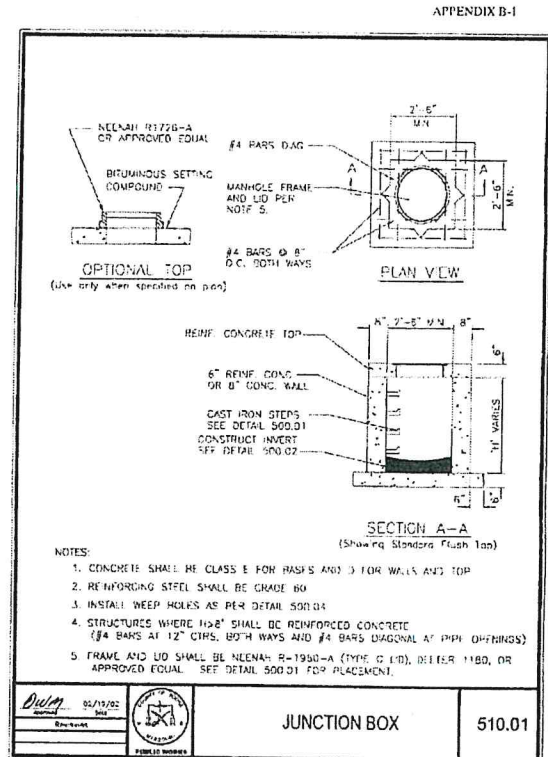

201

REQUEST FOR QUOTATION FOR FURNISHING STORMWATER MATERIALS

APPENDIX B-1

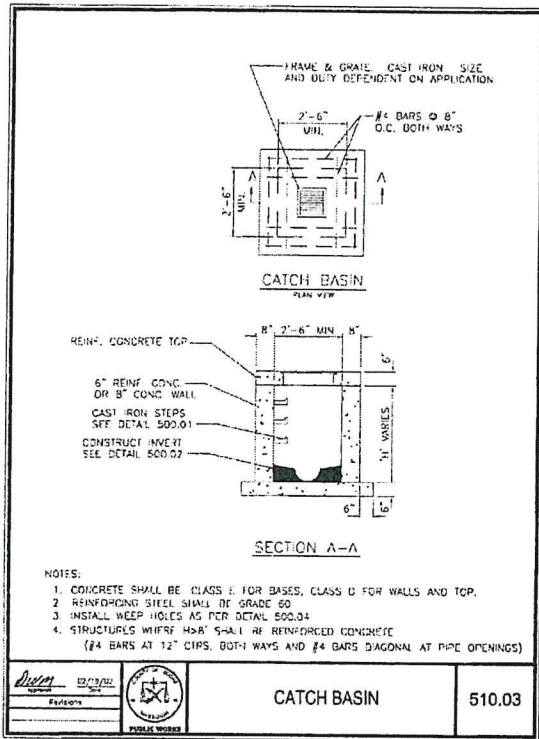

203



Water & Sewer Inc.

Date: 8/26/21
 Invoice #: N/A
 Customer ID:
 Expiration Date:

City of Ashland

Salesperson	Job	Payment Terms	Due Date
Adam Ransdell		Net 30 Days	

Qty	Description	Unit Price	Line Total
760.00	24" HDPE	\$ 21.35	\$ 16,226.00

Subtotal	\$	16,226.00
Sales Tax		
Total	\$	16,226.00

WATER & SEWER SUPPLY INC

Due to ongoing manufacture price increases, prices are subject to change without notice.

9-07-2021

A RESOLUTION AUTHORIZING THE MAYOR TO ENTER INTO AN AGREEMENT WITH CHRISTENSEN CONSTRUCTION CO. FOR THE MILL AND OVERLAY PROJECT; PROVIDING FOR COMPLIANCE WITH THE PREVAILING WAGE LAW AND STATE-MANDATED CONSTRUCTION SAFETY TRAINING

NOW THEREFORE BE IT RESOLVED BY THE BOARD OF ALDERMEN OF THE CITY OF ASHLAND, MISSOURI AS FOLLOWS:

Section 1. The Board of Aldermen hereby authorizes the Mayor, on behalf of the City of Ashland, to enter into a Christensen Construction, Co. for the Mill & Overlay Project. The form and content of the Agreement shall be substantially as set forth in the contract agreement.

Section 2. The contract for the improvement shall provide that not less than the prevailing hourly rate of wages, as determined by the Missouri Department of Labor and Industrial Relations of Missouri, shall be paid to all workers performing work under the contract.

Section 3. The contract for the improvement shall provide that the contractor and any subcontractor shall provide a ten-hour Occupational Safety and Health Administration construction safety program (or a similar program approved by the Missouri Department of Labor and Industrial Relations) for all employees working on-site. All employees working on the site of the improvement are required to complete the safety program within 60 days of beginning work on the improvement project.

Section 4. This ordinance shall be in full force and effect from and after its passage and approval.

Dated this _____ day of _____, 2021.

Richard Sullivan, Mayor

Attest:

Darla Sapp, City Clerk



Ashland Police Department

601 E Broadway - Ashland, MO 65010 ~ www.ashlandmo.us ~ Gabe Edwards, Police Chief ~ Telephone: 573-657-9062

APD Monthly Report to the Board of Alderman

For the September 7th, 2021 meeting

- **Vehicles and other police equipment**
 - 2014 Dodge Charger with 100,077 miles sold at auction on purplewave.com for \$5600
 - 2013 Ford Interceptor Sedan with 111,023 miles sold at auction on purplewave.com for \$4600
 - Two of three 2021 Dodge Durango Pursuits have been outfitted and placed into service.
 - The third and final Durango is at the installer's shop being built. Its completion will be delayed because our installer was deployed to Louisiana with Missouri Task Force One due to the recent hurricane.
- **Personnel**
 - We now have two vacancies;
 - One vacancy from new position authorized at the beginning of this FY
 - One vacancy stemming from a recent resignation
 - One applicant still in the background phase which was delayed due to the recent homicide investigation but is now back on track and nearly completed
 - One applicant who was in the background phase has withdrawn after the applicant was offered a job with another local police department
 - Another applicant in the wings with interviews forthcoming
- **General**
 - Discussion about letter to MoDOT from the city regarding our request for installation of traffic delineators at the intersection of Route Y and Eastside Drive



Ashland Police Department

601 E Broadway - Ashland, MO 65010 ~ www.ashlandmo.us ~ Gabe Edwards, Police Chief ~ Telephone: 573-657-9062

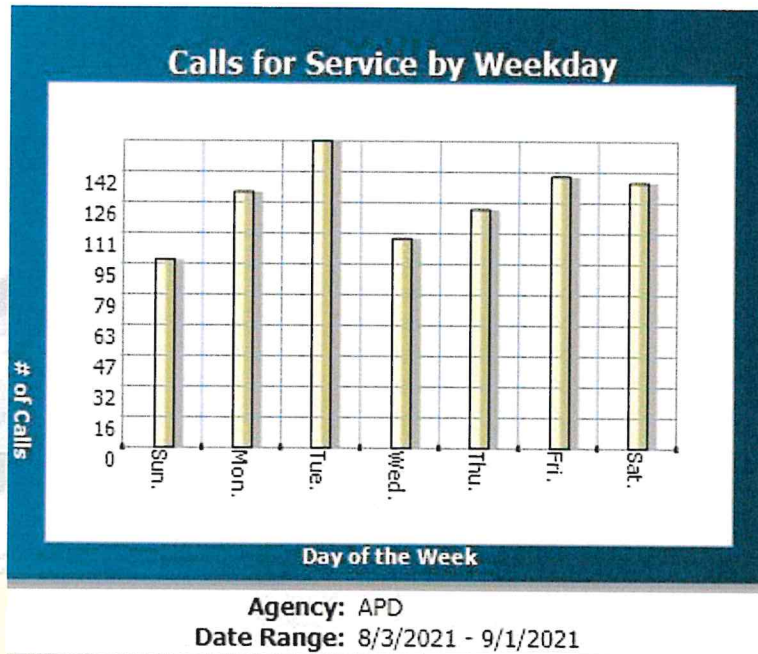

Statistics for the period of 08/03/2021 – 09/01/2021

Calls for Service:	295
Building Security Check:	38
Neighborhood Patrols:	381
Traffic stops:	113
Misdemeanor Arrests:	9
Felony Arrests:	10



Ashland Police Department

601 E Broadway - Ashland, MO 65010 ~ www.ashlandmo.us ~ Gabe Edwards, Police Chief ~ Telephone: 573-657-9062

Summons/Citations Charge Summary

Date Range: 08/03/2021 00:00:00 - 09/01/2021

<u>Charges</u>	<u>Count</u>
CHILD RESTRAINT VIOLATION	1
ENDANGERMENT OF HWY WORKER AS	1
EXCEEDED POSTED SPEED LIMIT	2
EXCEEDED POSTED SPEED LIMIT	1
IMPROPER TURNING	1
LEAVING THE SCENE OF ACCIDENT	1
NO PROOF OF INSURANCE	2
OPERATE VEHICLE ON HWY WITHOUT	1
OPERATING A VEHICLE WITH	1
PARKING PROHIBITED WHERE POSTED NO	1
SEAT BELT REQUIRED	4
SEAT BELT REQUIRED - PASSENGER	1
SPEEDING (11-15 MPH OVER)	1
SPEEDING (16-19 MPH OVER)	2
SPEEDING (20-25 MPH OVER)	6
SPEEDING (31-35 MPH OVER)	1
VIOLATE PROVISIONS OF SEC. 302.130 OR	1
WINDOW TINT VIOLATION	2
	<u>Total: 30</u>

